

VIBRATING SORTING TABLE

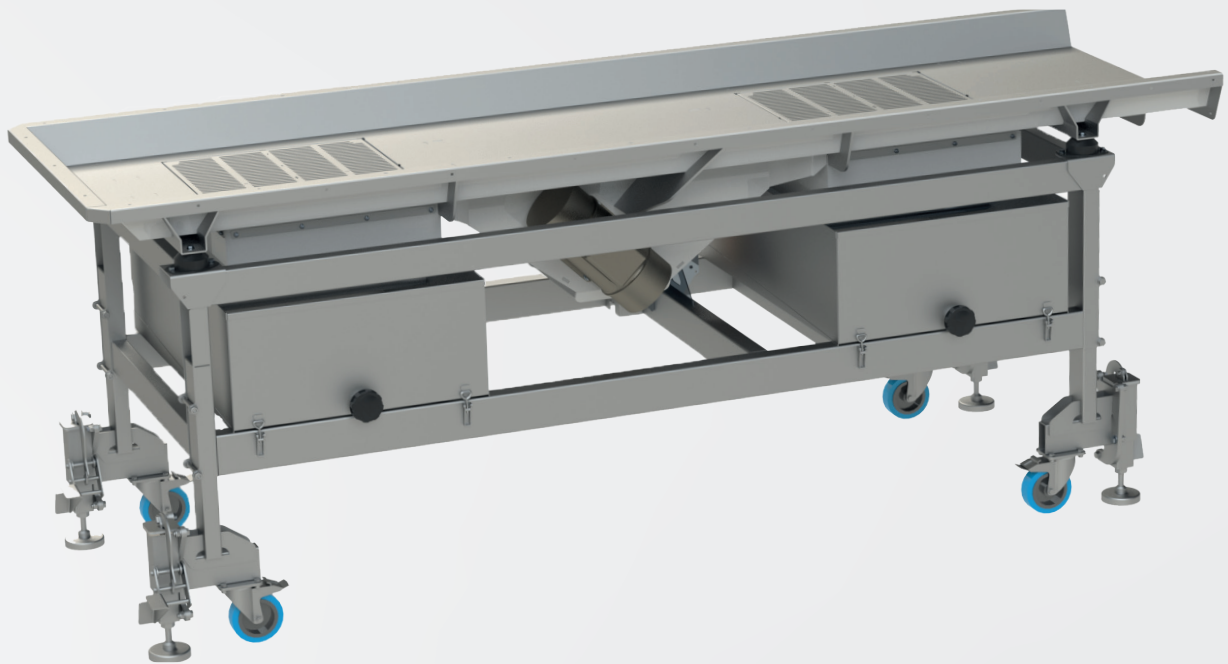

THE INNOVATIVE VIBRATING SORTING TABLE

Mounted on custom suspensions and equipped with vibrators and a 304 stainless steel vibrating trough with two perforated grids, it automatically removes small debris, dry grapes and insects, allowing manual sorting to be carried out by operators placed on either side of the machine.

Special features

- ▶ Stainless steel grids that can be removed in seconds without tools.
- ▶ Foot-operated retractable jacks stabilize the machine and separate the wheels from the ground.
- ▶ Two waste bins.
- ▶ An electronic variable speed drive.
- ▶ Microblasted finish.

Innovative options

- ▶ It has 2 sifting areas equipped with stainless steel grids perforated according to the customer's wishes. (3, 5 or 7mm).
- ▶ At its entrance, it is designed to receive any type of hopper in order to adapt to the previous equipment: bin with vibrating chute, crate, crate tipper, box.
- ▶ At its exit, it can be equipped with an adjustable chute that allows for a smooth descent to the subsequent equipment.
- ▶ Two automatic waste disposal ducts can be integrated.
- ▶ To increase the visibility of the material to be processed, it can be equipped with LED lighting (optional).
- ▶ Underneath the draining areas, drawers can be positioned to filter the juices through a grid that can be cleaned instantly thanks to its slide-out scraper.
- ▶ The user can dismantle the table into pieces in one minute and it takes no more than two minutes to reassemble it.

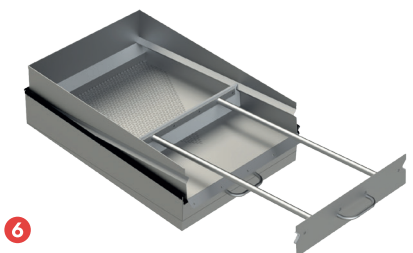
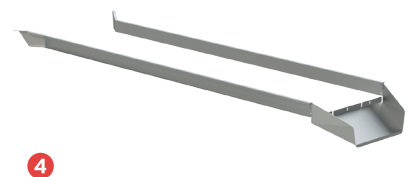
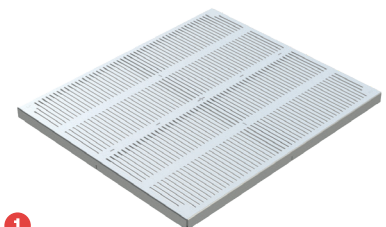
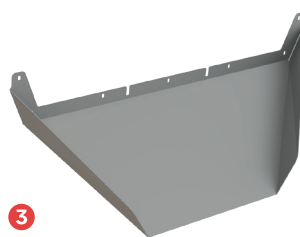
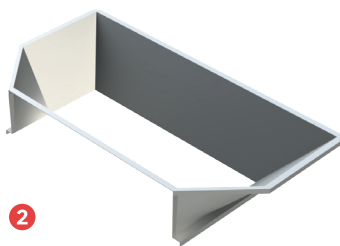

SUMMARY OF THE VIBRATING SORTING TABLE

Special features

- ▶ A remarkable standard of equipment.
- ▶ A tool that adapts to all configurations.
- ▶ Quality construction and a microblasted finish like the entire SOCMA range.

THE OPTIONS

1 Additional stainless steel grid

2 Wide intake hopper

3 Stainless steel output chute

4 Inner waste aisle with chute

5 LED light rail

6 2 juice collection trays

- ▶ 50mm mason drainage fitting
- ▶ Filter grids and cleaning scraper

SOCMA®

ZA du Castellas
599, avenue du Col de Chèvre
11100 Montredon-des-Corbières

+33 (0)4 68 41 50 30
socma@socma.info
socma.info

1st prize Innovation Ingenuity DYONISUD 2004