

CRATE WASHER

A TOOL OF ECOLOGICAL AND ECONOMIC INTEREST



COMPOSITION

- ▶ A chassis, a housing and a 250 L bin, all in stainless steel.
- ▶ Washing ramps and a guidance system, adjustable and adaptable to all types of crates.
- ▶ An automatic water level regulator.
- ▶ A solid waste separation drawer.
- ▶ An all stainless steel submersible pump.

A TOOL WITH MANY ADVANTAGES

- ▶ Effortless crate cleaning.
- ▶ Recovery and recycling of wash water.
- ▶ The possibility of independent use of the pump and the tank for various jobs.
- ▶ Complete draining of water lines.
- ▶ The use of cleaning products with no risk of damaging the machine.

A VERSATILE TOOL

- ▶ The independent 250 L tank can be used for other applications (mixing, or the preparation of small quantities).
- ▶ After the season ends, the 30 m³/h removable submersible pump can also be used for other work.

CRATE DIMENSIONS

Max. width	705 mm
Min. width	250 mm
Height	410 mm

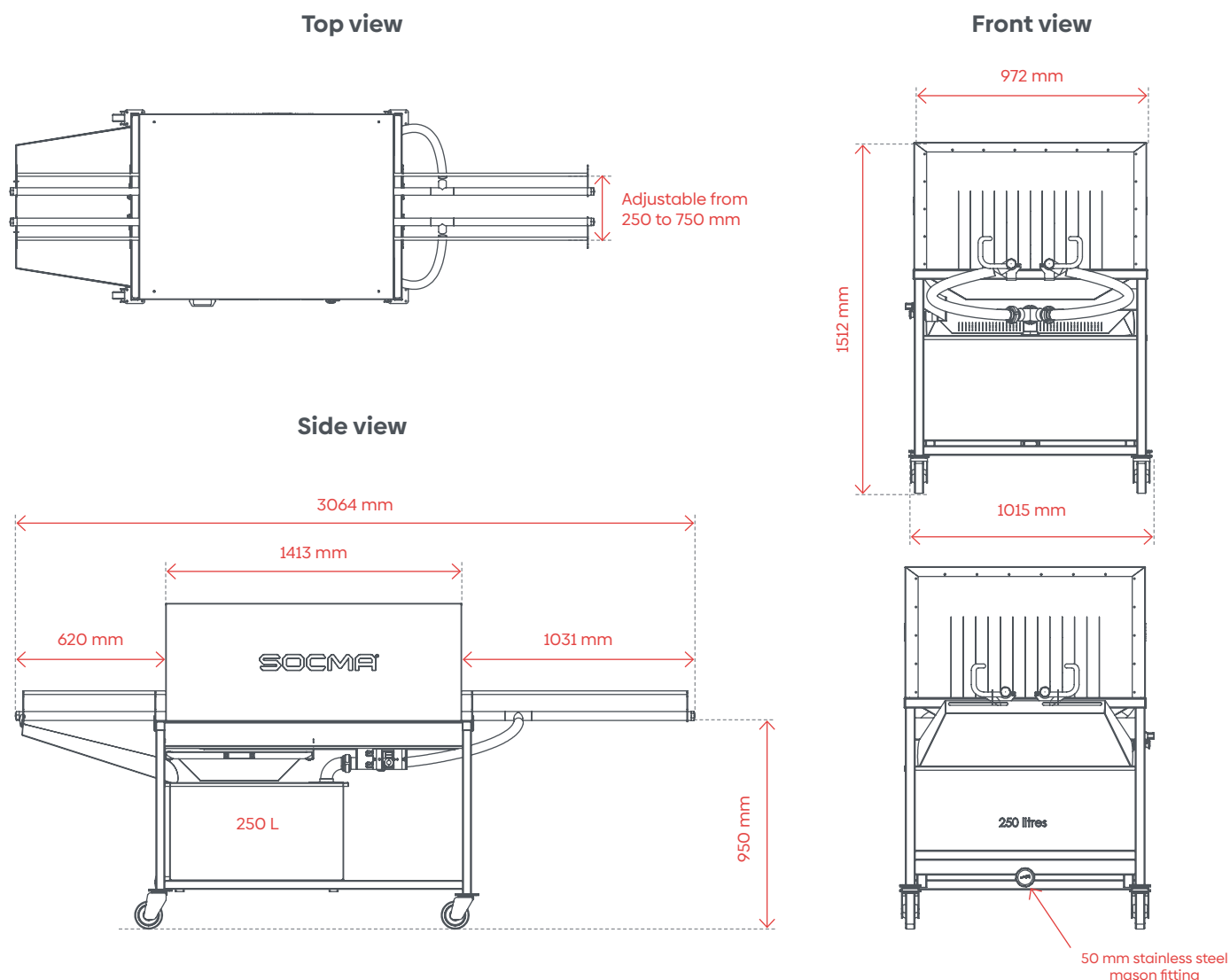

SOCMA®

ZA du Castellas
 599, avenue du Col de Chèvre
 11100 Montredon-des-Corbières

+33 (0)4 68 41 50 30
 socma@socma.info
 socma.info