

CRUSHER



A CRUSHER WITH MANY ADVANTAGES

- ▶ Thanks to the integrated motor in one of the rollers, it is compact and light.
- ▶ The covers can be removed without the use of tools, making it easy to clean.
- ▶ With its unique adjustment knob, its effect on the grapes is perfectly controlled, keeping the rollers consistently parallel.
- ▶ Unparalleled crush quality.
- ▶ Great care is taken with the fruit thanks to the materials used.
- ▶ Unique adaptability to fit any configuration.

COMPOSITION

- ▶ Covered motorised drum.
- ▶ Drum driven by a large tooth sprocket.
- ▶ Custom flexible food-grade coverings.
- ▶ Spacing adjustment knob.
- ▶ Removable bonnet held by latches.
- ▶ IP55 Junction box.

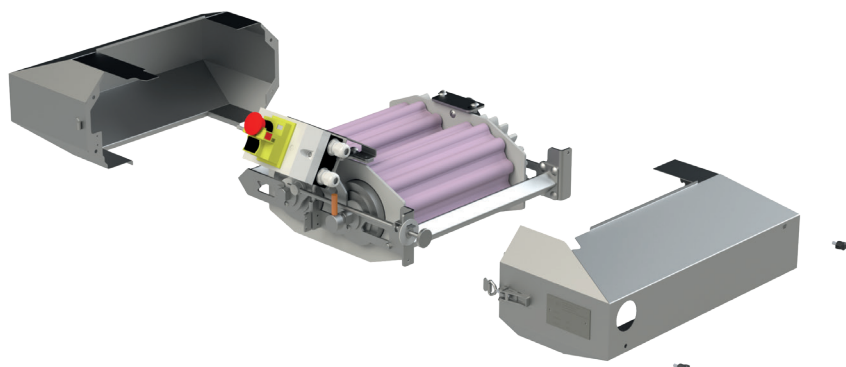

Crusher with covers removed

DIMENSIONS BY MODEL

Models	Dimensions IN MM
Large model DESTEMMED HARVEST	650x460x230
Large model WHOLE CLUSTER HARVEST	640x494x254
Small model DESTEMMED HARVEST	500x460x230
Small model WHOLE CLUSTER HARVEST	490x494x254

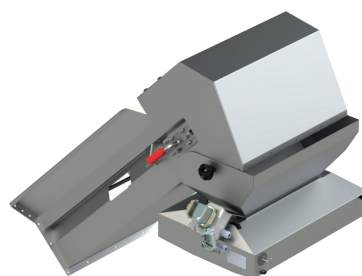

Crusher at the end of the conveyor belt



Crusher on mobile chassis

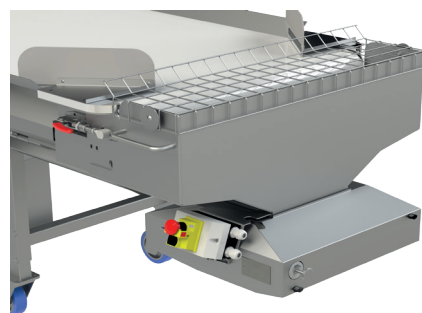

Suspended crusher

SOCMA®

ZA du Castellas
599, avenue du Col de Chèvre
11100 Montredon-des-Corbières

+33 (0)4 68 41 50 30
socma@socma.info
socma.info