

CYLINDRICAL TANK



ADVANTAGES

- ▶ Maneuverability.
- ▶ Versatility (transport of the harvest: whole, destemmed or fermented).
- ▶ A mechanism that enables opening and closing without the need for pneumatics, hydraulics or electricity.

OPTIONAL EQUIPMENT

- ▶ Remote opening and closing system.

COMPOSITION

- ▶ 600 L stainless steel tank.
- ▶ 1 upper reinforcement collar.
- ▶ 1 double handle for manipulation.
- ▶ 1 watertight gate with a 550 mm diameter.
- ▶ 4 swivel castors.
- ▶ Forklift pockets for transport and elevation.
- ▶ Microblasted stainless steel construction.

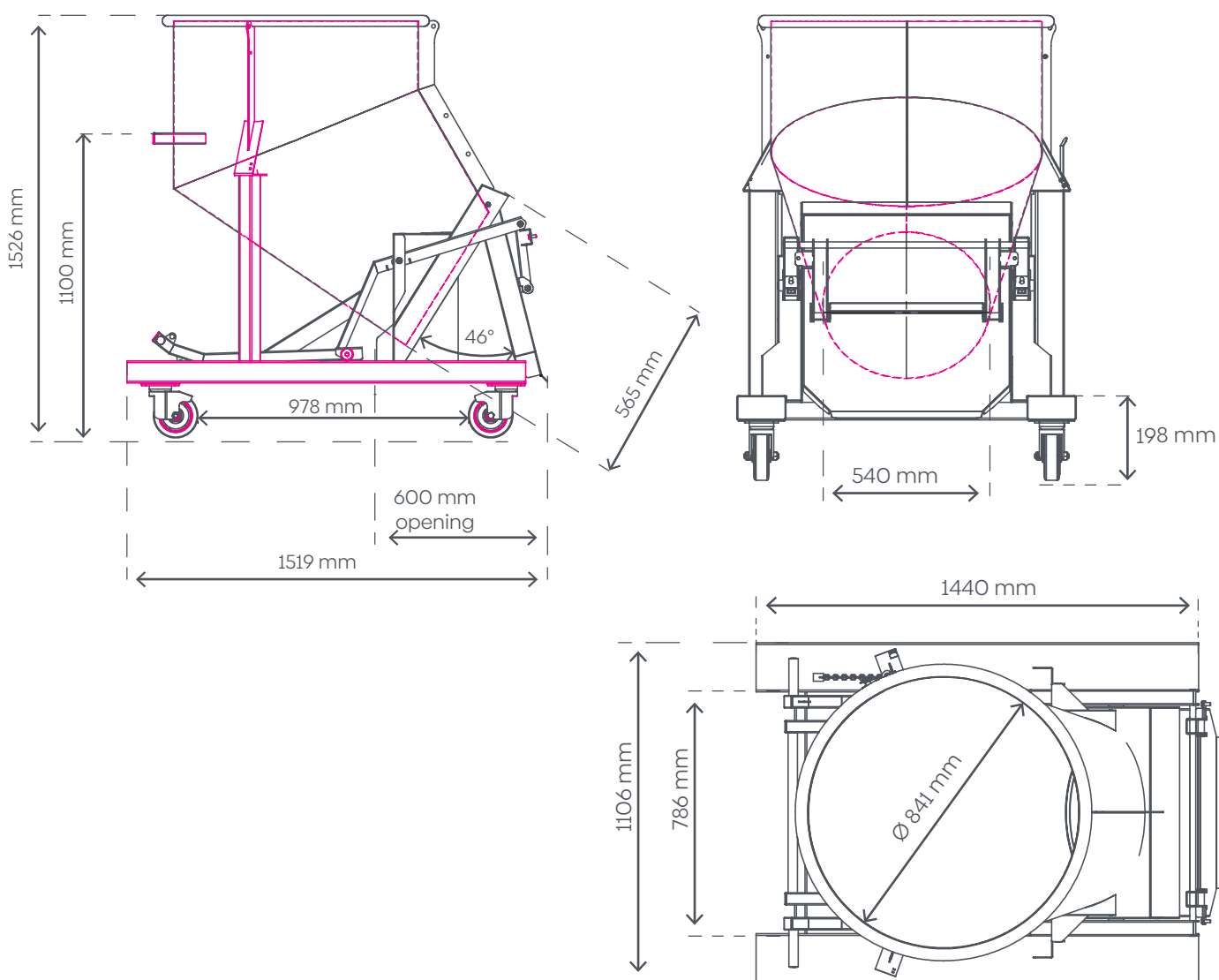

SOCMA®

ZA du Castellas
599, avenue du Col de Chèvre
11100 Montredon-des-Corbières

+33 (0)4 68 41 50 30
socma@socma.info
socma.info