

# TILTING TANK



# THE TILTING TANK

Our mobile tank enables the transport of grape pomace or the harvest into the vat. Its tilting system allows the flow rate to be controlled when transferring the harvest from the tank to the vat.

## ADVANTAGES

- Mobile tank that can be easily moved.
- Can feed a conveyor belt, a crusher, a press or a vat.
- Regulates the flow of the harvest.

## COMPOSITION

- 304 stainless steel microblasted housing.
- Microblasted stainless steel chassis on stainless steel yoked castors with rubber tires.
- Forklift pockets for elevation.
- Hydraulic tilting system.
- Hydraulic hand pump.
- Single-acting cylinder.
- Tank capacity: 350 or 500 L.

### Right side view

Lowered position

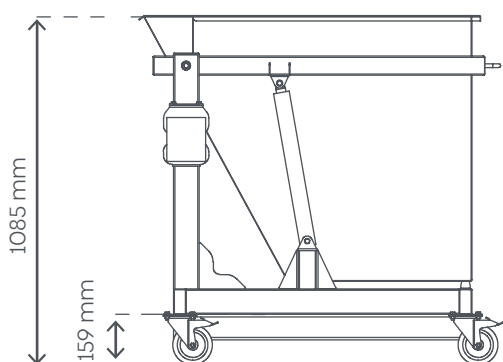

### Front view

Lowered position

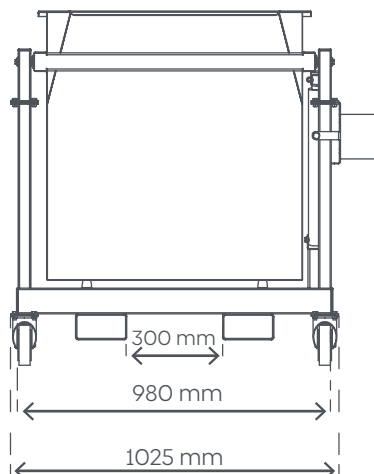

### Right side view

Emptying position

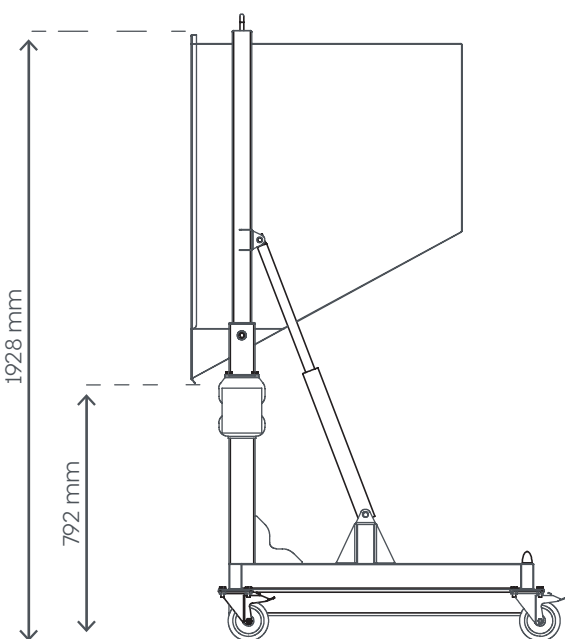

### Top view

Lowered position

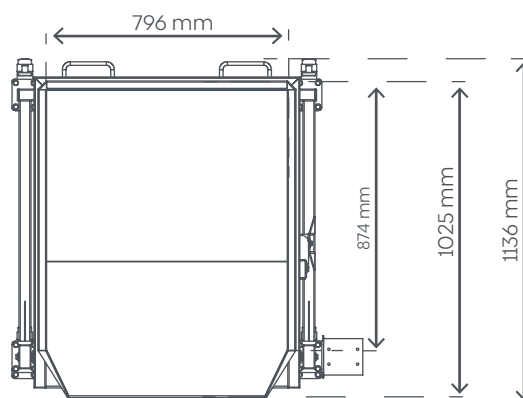

**SOCMA®**

ZA du Castellas  
599, avenue du Col de Chèvre  
11100 Montredon-des-Corbières

+33 (0)4 68 41 50 30  
socma@socma.info  
socma.info